



Think electric.

The new generation
in skid steer loaders.

ELISE 900

kovacoelectric.com

**More than
a loader, it's
an integrated
concept.**

Thanks to constant innovations, we strive to be one step ahead at KOVACO ELECTRIC. We believe in the power of simplicity, which is why we have developed new types of 100% electric skid steer loaders. Powerful devices with up to 8 hours endurance on a single charge, zero negative impact on the environment and minimal maintenance costs and down time.



Powered with technology



ELISE 900. The world's first electric skid steer loader represents the highest technology and years of experience of Kovaco Electric.

Battery endurance

2-6_h

8+ hours
with extended battery

Hinge pin height

143.19_{inch}

356mm/14 inch higher reach than
the competing average

Side tilt

47°

10° higher tilt angle
than competing average



ogy.

Extensive safety features

Ground breaking powertrain

Micro speed for precision maneuverability

Self-levelling gyro platform

Extremely low operating cost

Minimal maintenance

100% Eco-friendly

Chassis Clearance

10.3 inch

44mm/1.73 inch higher
than competing average

Remote Control

164 feet

164 feet operating radius
and 15m/ 49 feet with smart app

Loading capacity

1984 lbs

and 1400kg/3086lbs when using
400Ah extended battery

With **zero**
enviromental
impact.



Technical specs.



GENERAL SPECIFICATIONS	IMPERIAL
Rated load capacity	1 984 lb
Tipping load	3 968 lb
Minimum travel speed	0.09 mph
Maximum travel speed	7.49 mph
Hinge Pin Height	143 in

ENGINE	IMPERIAL
Electric engine type	3xGEW
Rated power	3x14.41 HP
Maximum power	3x36.21 HP
Maximum torque	3x88.51 lb ft

TUNE-UP YOUR MACHINE

- Extended battery 96V/400Ah
- 1 Phase Universal "ZIVAN" Charger
- Integrated Charger
- Left / Right Parking Camera
- Open Door Sensor
- ISO Joystick Remote Control - 433 MHz Radio
- No Window Cabin Re-build Set
- Air conditioning
- 30+ Attachments

STANDARD FEATURES

Basic bucket, Samsung Phone with proprietary control app, Proprietary bucket self-leveling system, Quick coupler – SAE J2513, Danfoss Hydraulics, Lead-acid battery – 96V/240Ah with 3 phase 50Ah Charger, FOPS & ROPS Safety Cabin, Seat with safety belt and operator detection system, ISO Joystick Control, Cabin Heating, Rear-view camera and reverse alarm, Front roller sunshade, Tinted glass, Opening sunroof, Windshield wiper with sprayer, Left and Right rear-view mirror

Compare technical specifications for this product online at www.kovacoelectric.com

ELISE 900

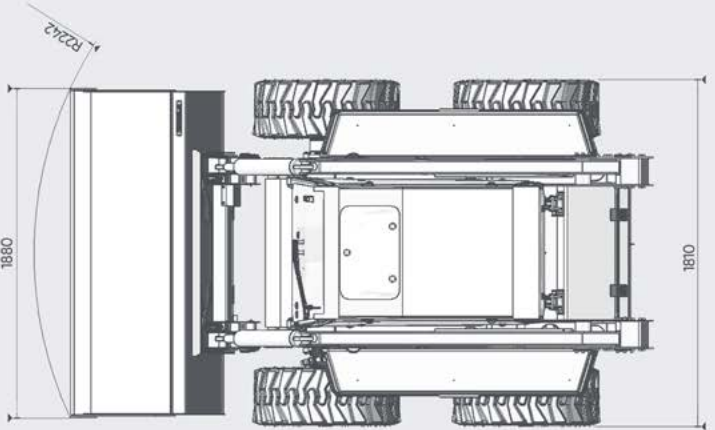
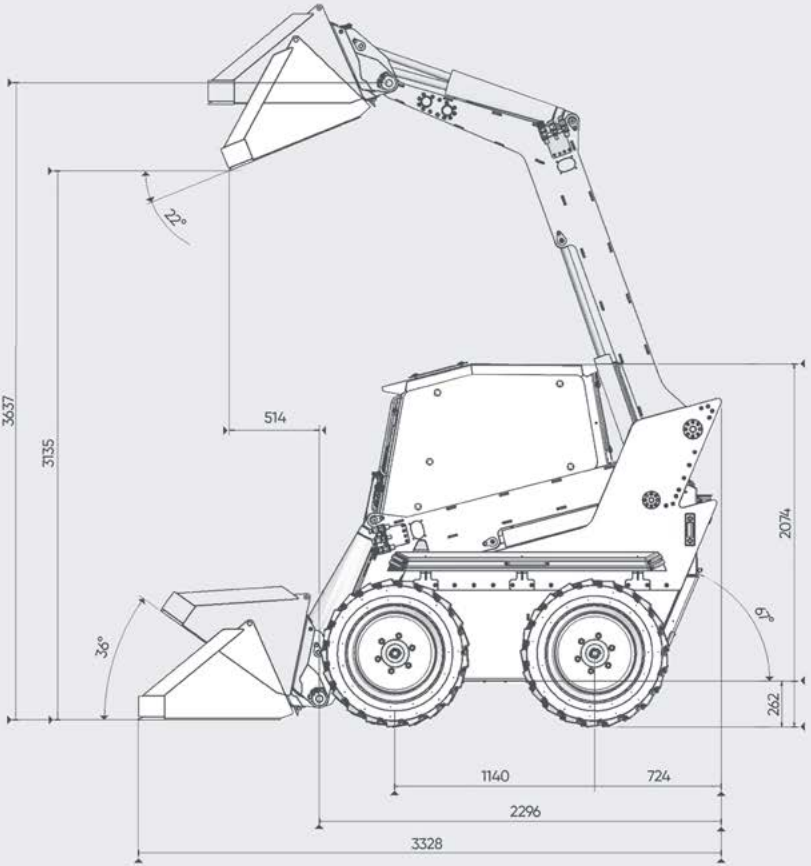

WEIGHTS **IMPERIAL**

Rated operating weight	7275 lb
Total weight of the loader	9259 lb

HYDRAULICS **IMPERIAL**

Hydraulic oil pressure	2610 psi
Hydraulic oil flow	17.17 gal/min
Hydraulic oil reservoir	10.57 gal

Maintenance



Logistics



Construction



Forestry



Agriculture



With a wide range of attachments.



4 in 1 bucket



Snowblower



Pallet forks



Tree cutter



Wood Splitter



... plus 34 other attachments
on kovacoelectric.com

+420 737 633 733

info@kovacoelectric.com



Need something smaller but just as powerful?

For more Kovaco Electric products, visit:

www.kovacoelectric.com

